

**EE : ELECTRICAL ENGINEERING**

Duration: Three Hours

Maximum Marks: 100

**Read the following instructions carefully.**

1. Do not open the seal of the Question Booklet until you are asked to do so by the invigilator.
2. Take out the **Optical Response Sheet (ORS)** from this Question Booklet **without breaking the seal** and read the instructions printed on the **ORS** carefully. If you find that the Question Booklet Code printed at the right hand top corner of this page does not match with the Booklet Code on the **ORS**, exchange the booklet immediately with a new sealed Question Booklet.
3. On the right half of the **ORS**, using **ONLY a black ink ball point pen**, (i) darken the bubble corresponding to your test paper code and the appropriate bubble under each digit of your registration number and (ii) write your registration number, your name and name of the examination centre and put your signature at the specified location.
4. This Question Booklet contains **20** pages including blank pages for rough work. After you are permitted to open the seal, please check all pages and report discrepancies, if any, to the invigilator.
5. There are a total of 65 questions carrying 100 marks. All these questions are of objective type. Each question has only **one** correct answer. Questions must be answered on the left hand side of the **ORS** by darkening the appropriate bubble (marked A, B, C, D) using **ONLY a black ink ball point pen** against the question number. **For each question darken the bubble of the correct answer.** More than one answer bubbled against a question will be treated as an incorrect response.
6. Since bubbles darkened by the black ink ball point pen **cannot** be erased, candidates should darken the bubbles in the **ORS very carefully.**
7. Questions Q.1 – Q.25 carry 1 mark each. Questions Q.26 – Q.55 carry 2 marks each. The 2 marks questions include two pairs of common data questions and two pairs of linked answer questions. The answer to the second question of the linked answer questions depends on the answer to the first question of the pair. If the first question in the linked pair is wrongly answered or is unattempted, then the answer to the second question in the pair will not be evaluated.
8. Questions Q.56 – Q.65 belong to General Aptitude (GA) section and carry a total of 15 marks. Questions Q.56 – Q.60 carry 1 mark each, and questions Q.61 – Q.65 carry 2 marks each.
9. Unattempted questions will result in zero mark and wrong answers will result in **NEGATIVE** marks. For all 1 mark questions,  $\frac{1}{3}$  mark will be deducted for each wrong answer. For all 2 marks questions,  $\frac{2}{3}$  mark will be deducted for each wrong answer. However, in the case of the linked answer question pair, there will be negative marks only for wrong answer to the first question and no negative marks for wrong answer to the second question.
10. Calculator is allowed whereas charts, graph sheets or tables are **NOT** allowed in the examination hall.
11. Rough work can be done on the question paper itself. Blank pages are provided at the end of the question paper for rough work.
12. Before the start of the examination, write your name and registration number in the space provided below using a black ink ball point pen.

<b>Name</b>								
<b>Registration Number</b>	<b>EE</b>							

**Q. 1 – Q. 25 carry one mark each.**

Q.1 Two independent random variables X and Y are uniformly distributed in the interval  $[-1, 1]$ . The probability that  $\max[X, Y]$  is less than  $1/2$  is

- (A)  $3/4$  (B)  $9/16$  (C)  $1/4$  (D)  $2/3$

Q.2 If  $x = \sqrt{-1}$ , then the value of  $x^x$  is

- (A)  $e^{-\pi/2}$  (B)  $e^{\pi/2}$  (C)  $x$  (D)  $1$

Q.3 Given

$f(z) = \frac{1}{z+1} - \frac{2}{z+3}$ . If C is a counterclockwise path in the z-plane such that  $|z+1|=1$ , the value of  $\frac{1}{2\pi j} \oint_C f(z) dz$  is

- (A)  $-2$  (B)  $-1$  (C)  $1$  (D)  $2$

Q.4 In the circuit shown below, the current through the inductor is

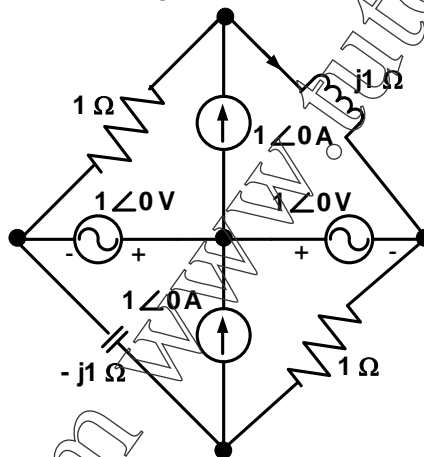

- (A)  $\frac{2}{1+j}$  A (B)  $\frac{-1}{1+j}$  A (C)  $\frac{1}{1+j}$  A (D)  $0$  A

Q.5 The impedance looking into nodes 1 and 2 in the given circuit is

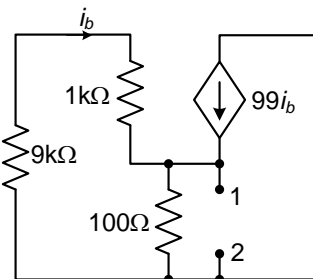

- (A)  $50 \Omega$  (B)  $100 \Omega$  (C)  $5 \text{ k}\Omega$  (D)  $10.1 \text{ k}\Omega$

Q.6 A system with transfer function

$$G(s) = \frac{(s^2 + 9)(s + 2)}{(s + 1)(s + 3)(s + 4)}$$

is excited by  $\sin(\omega t)$ . The steady-state output of the system is zero at

- (A)  $\omega = 1 \text{ rad/s}$  (B)  $\omega = 2 \text{ rad/s}$   
 (C)  $\omega = 3 \text{ rad/s}$  (D)  $\omega = 4 \text{ rad/s}$

Q.7 In the sum of products function  $f(X, Y, Z) = \sum(2, 3, 4, 5)$ , the prime implicants are

- (A)  $\bar{X}Y, X\bar{Y}$  (B)  $\bar{X}Y, X\bar{Y}\bar{Z}, X\bar{Y}Z$   
 (C)  $\bar{X}Y\bar{Z}, \bar{X}YZ, X\bar{Y}$  (D)  $\bar{X}Y\bar{Z}, \bar{X}YZ, X\bar{Y}\bar{Z}, X\bar{Y}Z$

Q.8 If  $x[n] = (1/3)^{|n|} - (1/2)^n u[n]$ , then the region of convergence (ROC) of its Z-transform in the Z-plane will be

- (A)  $\frac{1}{3} < |z| < 3$  (B)  $\frac{1}{3} < |z| < \frac{1}{2}$  (C)  $\frac{1}{2} < |z| < 3$  (D)  $\frac{1}{3} < |z| < \frac{1}{2}$

Q.9 The bus admittance matrix of a three-bus three-line system is

$$Y = j \begin{bmatrix} -13 & 10 & 5 \\ 10 & -18 & 10 \\ 5 & 10 & -13 \end{bmatrix}$$

If each transmission line between the two buses is represented by an equivalent  $\pi$ -network, the magnitude of the shunt susceptance of the line connecting bus 1 and 2 is

- (A) 4 (B) 2 (C) 1 (D) 0

Q.10 The slip of an induction motor normally does not depend on

- (A) rotor speed (B) synchronous speed  
 (C) shaft torque (D) core-loss component

Q.11 A two-phase load draws the following phase currents:  $i_1(t) = I_m \sin(\omega t - \phi_1)$ ,  $i_2(t) = I_m \cos(\omega t - \phi_2)$ . These currents are balanced if  $\phi_1$  is equal to

- (A)  $-\phi_2$  (B)  $\phi_2$  (C)  $(\pi/2 - \phi_2)$  (D)  $(\pi/2 + \phi_2)$

Q.12 A periodic voltage waveform observed on an oscilloscope across a load is shown. A permanent magnet moving coil (PMMC) meter connected across the same load reads

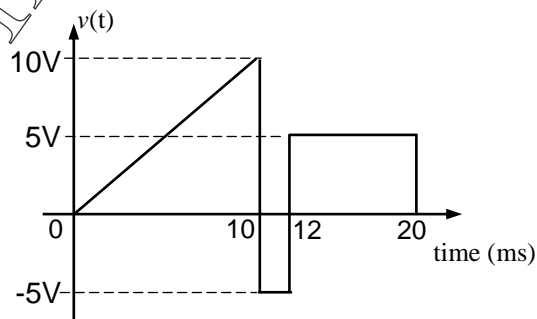

- (A) 4 V (B) 5 V (C) 8 V (D) 10 V

Q.13 The bridge method commonly used for finding mutual inductance is

- (A) Heaviside Campbell bridge (B) Schering bridge  
 (C) De Sauty bridge (D) Wien bridge

Q.14 With initial condition  $x(1) = 0.5$ , the solution of the differential equation

$$t \frac{dx}{dt} + x = t \text{ is}$$

- (A)  $x = t - \frac{1}{2}$       (B)  $x = t^2 - \frac{1}{2}$       (C)  $x = \frac{t^2}{2}$       (D)  $x = \frac{t}{2}$

Q.15 The unilateral Laplace transform of  $f(t)$  is  $\frac{1}{s^2 + s + 1}$ . The unilateral Laplace transform of  $tf(t)$  is

- (A)  $-\frac{s}{(s^2 + s + 1)^2}$       (B)  $-\frac{2s + 1}{(s^2 + s + 1)^2}$   
 (C)  $\frac{s}{(s^2 + s + 1)^2}$       (D)  $\frac{2s + 1}{(s^2 + s + 1)^2}$

Q.16 The average power delivered to an impedance  $(4 - j3) \Omega$  by a current  $5\cos(100\pi t + 100)$  A is

- (A) 44.2 W      (B) 50 W      (C) 62.5 W      (D) 125 W

Q.17 In the following figure,  $C_1$  and  $C_2$  are ideal capacitors.  $C_1$  has been charged to 12 V before the ideal switch S is closed at  $t = 0$ . The current  $i(t)$  for all  $t$  is

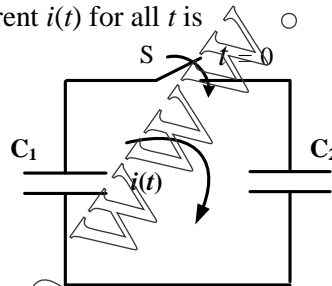

- (A) zero      (B) a step function  
 (C) an exponentially decaying function      (D) an impulse function

Q.18 The  $i$ - $v$  characteristics of the diode in the circuit given below are

$$i = \begin{cases} \frac{v - 0.7}{500} \text{ A, } & v \geq 0.7 \text{ V} \\ 0 \text{ A, } & v < 0.7 \text{ V} \end{cases}$$

The current in the circuit is

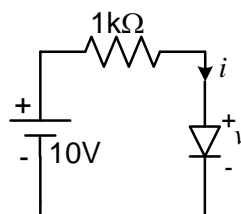

- (A) 10 mA      (B) 9.3 mA      (C) 6.67 mA      (D) 6.2 mA

Q.19 The output Y of a 2-bit comparator is logic 1 whenever the 2-bit input A is greater than the 2-bit input B. The number of combinations for which the output is logic 1, is

- (A) 4      (B) 6      (C) 8      (D) 10

Q.20 Consider the given circuit.

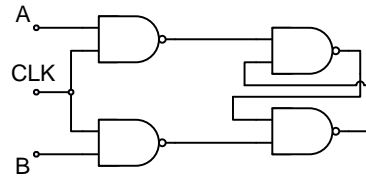

In this circuit, the race around

- (A) does not occur  
 (B) occurs when  $CLK = 0$   
 (C) occurs when  $CLK = 1$  and  $A = B = 1$   
 (D) occurs when  $CLK = 1$  and  $A = B = 0$

Q.21 The figure shows a two-generator system supplying a load of  $P_D = 40$  MW, connected at bus 2.

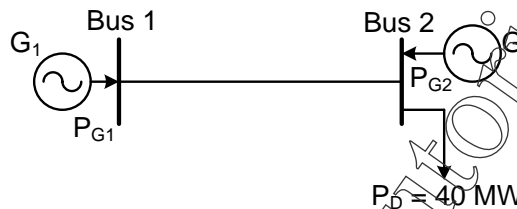

The fuel cost of generators  $G_1$  and  $G_2$  are :

$$C_1(P_{G1}) = 10,000 \text{ Rs/MWh and } C_2(P_{G2}) = 12,500 \text{ Rs/MWh}$$

and the loss in the line is  $P_{loss(pu)} = 0.5 P_{G1}^2(pu)$ , where the loss coefficient is specified in pu on a 100 MVA base. The most economic power generation schedule in MW is

- (A)  $P_{G1} = 20, P_{G2} = 22$   
 (B)  $P_{G1} = 22, P_{G2} = 20$   
 (C)  $P_{G1} = 20, P_{G2} = 20$   
 (D)  $P_{G1} = 0, P_{G2} = 40$

Q.22 The sequence components of the fault current are as follows:  $I_{positive} = j1.5$  pu,  $I_{negative} = -j0.5$  pu,  $I_{zero} = -j1$  pu. The type of fault in the system is

- (A) LG (B) LL (C) LLG (D) LLLG

Q.23 A half-controlled single-phase bridge rectifier is supplying an R-L load. It is operated at a firing angle  $\alpha$  and the load current is continuous. The fraction of cycle that the freewheeling diode conducts is

- (A)  $\frac{1}{2}$  (B)  $(1 - \frac{\alpha}{\pi})$  (C)  $\frac{\alpha}{2\pi}$  (D)  $\frac{\alpha}{\pi}$

Q.24 The typical ratio of latching current to holding current in a 20 A thyristor is

- (A) 5.0  
 (B) 2.0  
 (C) 1.0  
 (D) 0.5

- Q.25 For the circuit shown in the figure, the voltage and current expressions are  $v(t) = E_1 \sin(\omega t) + E_3 \sin(3\omega t)$  and  $i(t) = I_1 \sin(\omega t - \phi_1) + I_3 \sin(3\omega t - \phi_3) + I_5 \sin(5\omega t)$ . The average power measured by the Wattmeter is

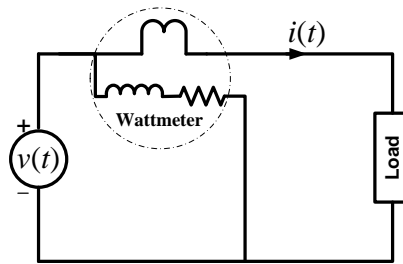

- (A)  $\frac{1}{2} E_1 I_1 \cos \phi_1$  (B)  $\frac{1}{2} [E_1 I_1 \cos \phi_1 + E_3 I_3 \cos \phi_3 + E_5 I_5]$   
 (C)  $\frac{1}{2} [E_1 I_1 \cos \phi_1 + E_3 I_3 \cos \phi_3]$  (D)  $\frac{1}{2} [E_1 I_1 \cos \phi_1 + E_3 I_1 \cos \phi_1]$

**Q. 26 to Q. 55 carry two marks each.**

Q.26 Given that

$A = \begin{bmatrix} -5 & -3 \\ 2 & 0 \end{bmatrix}$  and  $I = \begin{bmatrix} 1 & 0 \\ 0 & 1 \end{bmatrix}$ , the value of  $A^2$  is

- (A)  $15A + 12I$  (B)  $19A + 30I$   
 (C)  $17A + 15I$  (D)  $17A + 21I$

Q.27 The maximum value of  $f(x) = x^3 - 9x^2 + 24x + 5$  in the interval  $[1, 6]$  is

- (A) 21 (B) 25 (C) 41 (D) 46

Q.28 If  $V_A - V_B = 6 \text{ V}$ , then  $V_C - V_D$  is

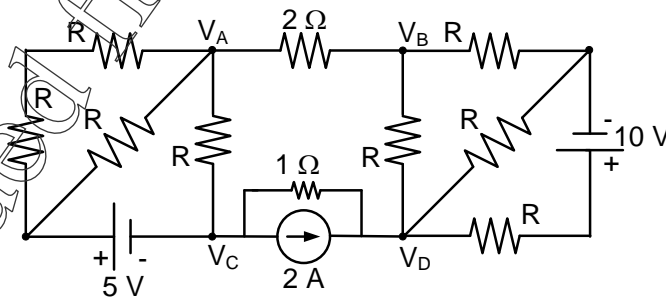

- (A) -5 V (B) 2 V (C) 3 V (D) 6 V

Q.29 The voltage gain  $A_v$  of the circuit shown below is

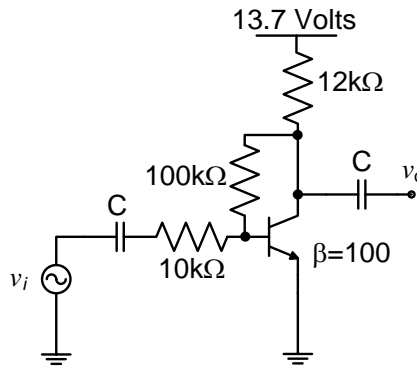

- (A)  $|A_v| \approx 200$       (B)  $|A_v| \approx 100$       (C)  $|A_v| \approx 20$       (D)  $|A_v| \approx 10$

Q.30 The state transition diagram for the logic circuit shown is

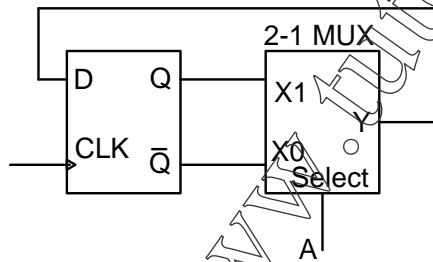

- (A)
- (B)
- (C)
- (D)

Q.31 Let  $y[n]$  denote the convolution of  $h[n]$  and  $g[n]$ , where  $h[n] = (1/2)^n u[n]$  and  $g[n]$  is a causal sequence. If  $y[0] = 1$  and  $y[1] = 1/2$ , then  $g[1]$  equals

- (A) 0      (B) 1/2      (C) 1      (D) 3/2

Q.32 The circuit shown is a

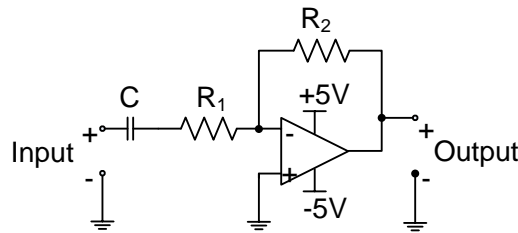

- (A) low pass filter with  $f_{3dB} = \frac{1}{(R_1 + R_2)C}$  rad/s  
 (B) high pass filter with  $f_{3dB} = \frac{1}{R_1 C}$  rad/s  
 (C) low pass filter with  $f_{3dB} = \frac{1}{R_1 C}$  rad/s  
 (D) high pass filter with  $f_{3dB} = \frac{1}{(R_1 + R_2)C}$  rad/s

Q.33 For the system shown below,  $S_{D1}$  and  $S_{D2}$  are complex power demands at bus 1 and bus 2 respectively. If  $|V_2| = 1$  pu, the VAR rating of the capacitor ( $Q_{G2}$ ) connected at bus 2 is

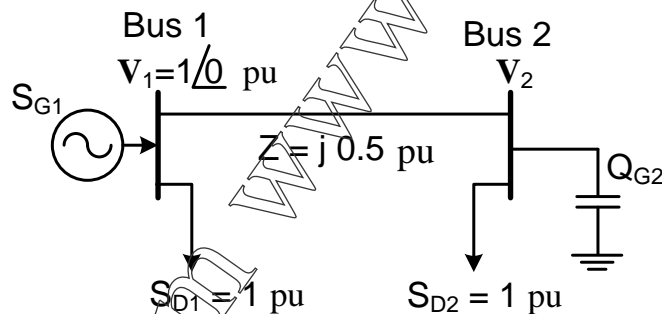

- (A) 0.2 pu      (B) 0.268 pu      (C) 0.312 pu      (D) 0.4 pu

Q.34 A cylindrical rotor generator delivers 0.5 pu power in the steady-state to an infinite bus through a transmission line of reactance 0.5 pu. The generator no-load voltage is 1.5 pu and the infinite bus voltage is 1 pu. The inertia constant of the generator is 5 MW-s/MVA and the generator reactance is 1 pu. The critical clearing angle, in degrees, for a three-phase dead short circuit fault at the generator terminal is

- (A) 53.5      (B) 60.2      (C) 70.8      (D) 79.6

Q.35 In the circuit shown, an ideal switch S is operated at 100 kHz with a duty ratio of 50%. Given that  $\Delta i_c$  is 1.6 A peak-to-peak and  $I_0$  is 5 A dc, the peak current in S is

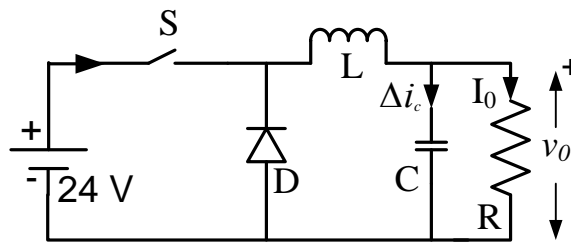

- (A) 6.6 A      (B) 5.0 A      (C) 5.8 A      (D) 4.2 A



Q.36 A 220 V, 15 kW, 1000 rpm shunt motor with armature resistance of  $0.25 \Omega$ , has a rated line current of 68 A and a rated field current of 2.2 A. The change in field flux required to obtain a speed of 1600 rpm while drawing a line current of 52.8 A and a field current of 1.8 A is

- (A) 18.18 % increase (B) 18.18 % decrease (C) 36.36 % increase (D) 36.36 % decrease

Q.37 A fair coin is tossed till a head appears for the first time. The probability that the number of required tosses is odd, is

- (A)  $1/3$  (B)  $1/2$  (C)  $2/3$  (D)  $3/4$

Q.38 The direction of vector  $\mathbf{A}$  is radially outward from the origin, with  $|\mathbf{A}| = k r^n$  where  $r^2 = x^2 + y^2 + z^2$  and  $k$  is a constant. The value of  $n$  for which  $\nabla \cdot \mathbf{A} = 0$  is

- (A)  $-2$  (B)  $2$  (C)  $1$  (D)  $0$

Q.39 Consider the differential equation

$$\frac{d^2 y(t)}{dt^2} + 2 \frac{dy(t)}{dt} + y(t) = \delta(t) \text{ with } y(t)|_{t=0^-} = -2 \text{ and } \frac{dy}{dt}|_{t=0} = 0.$$

The numerical value of  $\frac{dy}{dt}|_{t=0^+}$  is

- (A)  $-2$  (B)  $-1$  (C)  $0$  (D)  $1$

Q.40 Assuming both the voltage sources are in phase, the value of  $R$  for which maximum power is transferred from circuit A to circuit B is

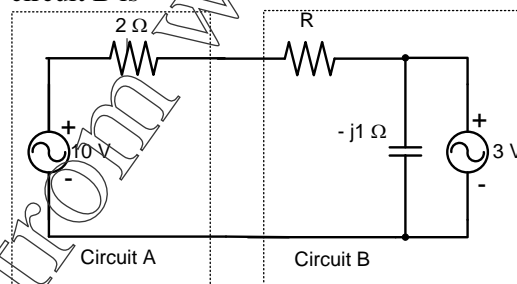

- (A)  $0.8 \Omega$  (B)  $1.4 \Omega$  (C)  $2 \Omega$  (D)  $2.8 \Omega$

Q.41 The state variable description of an LTI system is given by

$$\begin{pmatrix} \dot{x}_1 \\ \dot{x}_2 \\ \dot{x}_3 \end{pmatrix} = \begin{pmatrix} 0 & a_1 & 0 \\ 0 & 0 & a_2 \\ a_3 & 0 & 0 \end{pmatrix} \begin{pmatrix} x_1 \\ x_2 \\ x_3 \end{pmatrix} + \begin{pmatrix} 0 \\ 0 \\ 1 \end{pmatrix} u$$

$$y = \begin{pmatrix} 1 & 0 & 0 \end{pmatrix} \begin{pmatrix} x_1 \\ x_2 \\ x_3 \end{pmatrix}$$

where  $y$  is the output and  $u$  is the input. The system is controllable for

- (A)  $a_1 \neq 0, a_2 = 0, a_3 \neq 0$  (B)  $a_1 = 0, a_2 \neq 0, a_3 \neq 0$   
 (C)  $a_1 = 0, a_2 \neq 0, a_3 = 0$  (D)  $a_1 \neq 0, a_2 \neq 0, a_3 = 0$

Q.42 The Fourier transform of a signal  $h(t)$  is  $H(j\omega) = (2\cos\omega)(\sin 2\omega)/\omega$ . The value of  $h(0)$  is  
 (A) 1/4 (B) 1/2 (C) 1 (D) 2

Q.43 The feedback system shown below oscillates at 2 rad/s when

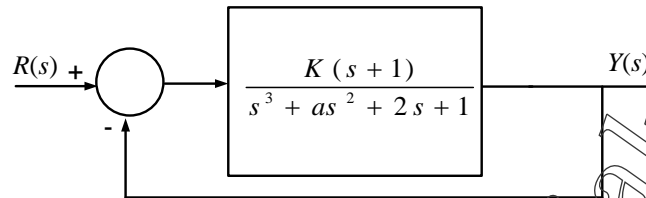

- (A)  $K = 2$  and  $a = 0.75$  (B)  $K = 3$  and  $a = 0.75$   
 (C)  $K = 4$  and  $a = 0.5$  (D)  $K = 2$  and  $a = 0.5$

Q.44 The input  $x(t)$  and output  $y(t)$  of a system are related as  $y(t) = \int_{-\infty}^t x(\tau) \cos(3\tau) d\tau$ . The system is

- (A) time-invariant and stable (B) stable and not time-invariant  
 (C) time-invariant and not stable (D) not time-invariant and not stable

Q.45 An analog voltmeter uses external multiplier settings. With a multiplier setting of 20 k $\Omega$ , it reads 440 V and with a multiplier setting of 80 k $\Omega$ , it reads 352 V. For a multiplier setting of 40 k $\Omega$ , the voltmeter reads

- (A) 371 V (B) 383 V (C) 394 V (D) 406 V

Q.46 The locked rotor current in a 3-phase, star connected 15 kW, 4-pole, 230 V, 50 Hz induction motor at rated conditions is 50 A. Neglecting losses and magnetizing current, the approximate locked rotor line current drawn when the motor is connected to a 236 V, 57 Hz supply is

- (A) 58.5 A (B) 45.0 A (C) 42.7 A (D) 55.6 A

Q.47 A single phase 10 kVA, 50 Hz transformer with 1 kV primary winding draws 0.5 A and 55 W, at rated voltage and frequency, on no load. A second transformer has a core with all its linear dimensions  $\sqrt{2}$  times the corresponding dimensions of the first transformer. The core material and lamination thickness are the same in both transformers. The primary windings of both the transformers have the same number of turns. If a rated voltage of 2 kV at 50 Hz is applied to the primary of the second transformer, then the no load current and power, respectively, are

- (A) 0.7 A, 77.8 W (B) 0.7 A, 155.6 W (C) 1 A, 110 W (D) 1 A, 220 W

## Common Data Questions

### Common Data for Questions 48 and 49:

In the 3-phase inverter circuit shown, the load is balanced and the gating scheme is  $180^\circ$ -conduction mode. All the switching devices are ideal.

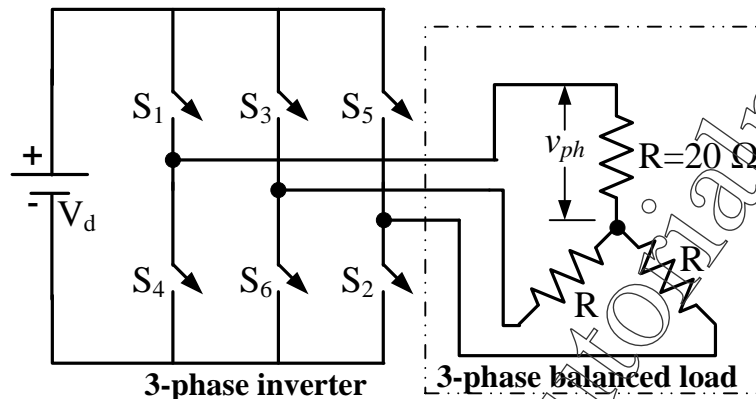

Q.48 The rms value of load phase voltage is

- (A) 106.1 V      (B) 141.4 V      (C) 212.2 V      (D) 282.8 V

Q.49 If the dc bus voltage  $V_d = 300$  V, the power consumed by 3-phase load is

- (A) 1.5 kW      (B) 2.0 kW      (C) 2.5 kW      (D) 3.0 kW

### Common Data for Questions 50 and 51:

With 10 V dc connected at port A in the linear nonreciprocal two-port network shown below, the following were observed:

- (i)  $1 \Omega$  connected at port B draws a current of 3 A  
 (ii)  $2.5 \Omega$  connected at port B draws a current of 2 A

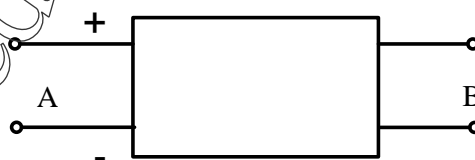

Q.50 For the same network, with 6 V dc connected at port A,  $1 \Omega$  connected at port B draws  $7/3$  A. If 8 V dc is connected to port A, the open circuit voltage at port B is

- (A) 6 V      (B) 7 V      (C) 8 V      (D) 9 V

Q.51 With 10 V dc connected at port A, the current drawn by  $7 \Omega$  connected at port B is

- (A)  $3/7$  A      (B)  $5/7$  A      (C) 1 A      (D)  $9/7$  A

### Linked Answer Questions

#### Statement for Linked Answer Questions 52 and 53:

In the circuit shown, the three voltmeter readings are  $V_1 = 220 \text{ V}$ ,  $V_2 = 122 \text{ V}$ ,  $V_3 = 136 \text{ V}$ .

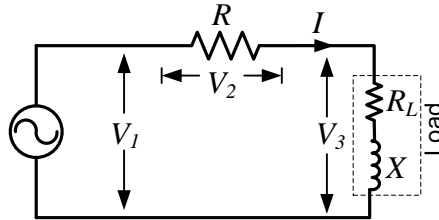

- Q.52 The power factor of the load is  
 (A) 0.45 (B) 0.50 (C) 0.55 (D) 0.60
- Q.53 If  $R_L = 5 \Omega$ , the approximate power consumption in the load is  
 (A) 700 W (B) 750 W (C) 800 W (D) 850 W

#### Statement for Linked Answer Questions 54 and 55:

The transfer function of a compensator is given as

$$G_c(s) = \frac{s+a}{s+b}$$

- Q.54  $G_c(s)$  is a lead compensator if  
 (A)  $a=1, b=2$  (B)  $a=3, b=2$   
 (C)  $a=-3, b=-1$  (D)  $a=3, b=1$
- Q.55 The phase of the above lead compensator is maximum at  
 (A)  $\sqrt{2}$  rad/s (B)  $\sqrt{3}$  rad/s (C)  $\sqrt{6}$  rad/s (D)  $1/\sqrt{3}$  rad/s

**General Aptitude (GA) Questions (Compulsory)****Q. 56 – Q. 60 carry one mark each.**

Q.56 One of the parts (A, B, C, D) in the sentence given below contains an ERROR. Which one of the following is **INCORRECT**?

**I requested that he should be given the driving test today instead of tomorrow.**

- (A) requested that
- (B) should be given
- (C) the driving test
- (D) instead of tomorrow

Q.57 If  $(1.001)^{1259} = 3.52$  and  $(1.001)^{2062} = 7.85$ , then  $(1.001)^{3321} =$

- (A) 2.23
- (B) 4.33
- (C) 11.37
- (D) 27.64

Q.58 Choose the most appropriate alternative from the options given below to complete the following sentence:

**If the tired soldier wanted to lie down, he \_\_\_ the mattress out on the balcony.**

- (A) should take
- (B) shall take
- (C) should have taken
- (D) will have taken

Q.59 Choose the most appropriate word from the options given below to complete the following sentence:

**Given the seriousness of the situation that he had to face, his \_\_\_ was impressive.**

- (A) beggary
- (B) nomenclature
- (C) jealousy
- (D) nonchalance

Q.60 Which one of the following options is the closest in meaning to the word given below?

**Latitude**

- (A) Eligibility
- (B) Freedom
- (C) Coercion
- (D) Meticulousness

**Q. 61 - Q. 65 carry two marks each.**

Q.61 A and B are friends. They decide to meet between 1 PM and 2 PM on a given day. There is a condition that whoever arrives first will not wait for the other for more than 15 minutes. The probability that they will meet on that day is

- (A) 1/4
- (B) 1/16
- (C) 7/16
- (D) 9/16

Q.62 **One of the legacies of the Roman legions was discipline. In the legions, military law prevailed and discipline was brutal. Discipline on the battlefield kept units obedient, intact and fighting, even when the odds and conditions were against them.**

Which one of the following statements best sums up the meaning of the above passage?

- (A) Thorough regimentation was the main reason for the efficiency of the Roman legions even in adverse circumstances.
- (B) The legions were treated inhumanly as if the men were animals.
- (C) Discipline was the armies' inheritance from their seniors.
- (D) The harsh discipline to which the legions were subjected to led to the odds and conditions being against them.

Q.63 Raju has 14 currency notes in his pocket consisting of only Rs. 20 notes and Rs. 10 notes. The total money value of the notes is Rs. 230. The number of Rs. 10 notes that Raju has is

- (A) 5
- (B) 6
- (C) 9
- (D) 10

Q.64 There are eight bags of rice looking alike, seven of which have equal weight and one is slightly heavier. The weighing balance is of unlimited capacity. Using this balance, the minimum number of weighings required to identify the heavier bag is

- (A) 2
- (B) 3
- (C) 4
- (D) 8

Q.65 The data given in the following table summarizes the monthly budget of an average household.

Category	Amount (Rs.)
Food	4000
Clothing	1200
Rent	2000
Savings	1500
Other expenses	1800

The approximate percentage of the monthly budget **NOT** spent on savings is

- (A) 10%
- (B) 14%
- (C) 81%
- (D) 86%

**END OF THE QUESTION PAPER**

**Space for Rough Work**

Downloaded from [www.tutorialpoint.org](http://www.tutorialpoint.org)

**Space for Rough Work**

Downloaded from [www.tutorialpoint.org](http://www.tutorialpoint.org)



**Space for Rough Work**

Downloaded from [www.tutorialpoint.org](http://www.tutorialpoint.org)

**Space for Rough Work**

Downloaded from [www.tutorialpoint.org](http://www.tutorialpoint.org)

**Space for Rough Work**

Downloaded from [www.tutorialpoint.org](http://www.tutorialpoint.org)

**Space for Rough Work**

Downloaded from [www.tutorialpoint.org](http://www.tutorialpoint.org)