

**ME : MECHANICAL ENGINEERING**

Duration: Three Hours

Maximum Marks: 100

**Read the following instructions carefully.**

1. Do not open the seal of the Question Booklet until you are asked to do so by the invigilator.
2. Take out the **Optical Response Sheet (ORS)** from this Question Booklet **without breaking the seal** and read the instructions printed on the ORS carefully. If you find that the Question Booklet Code printed at the right hand top corner of this page does not match with the Booklet Code on the **ORS**, exchange the booklet immediately with a new sealed Question Booklet.
3. On the right half of the **ORS**, using **ONLY a black ink ball point pen**, (i) darken the bubble corresponding to your test paper code and the appropriate bubble under each digit of your registration number and (ii) write your registration number, your name and name of the examination centre and put your signature at the specified location.
4. This Question Booklet contains **16** pages including blank pages for rough work. After you are permitted to open the seal, please check all pages and report discrepancies, if any, to the invigilator.
5. There are a total of 65 questions carrying 100 marks. All these questions are of objective type. Each question has only **one** correct answer. Questions must be answered on the left hand side of the **ORS** by darkening the appropriate bubble (marked A, B, C, D) using **ONLY a black ink ball point pen** against the question number. **For each question darken the bubble of the correct answer.** More than one answer bubbled against a question will be treated as an incorrect response.
6. Since bubbles darkened by the black ink ball point pen **cannot** be erased, candidates should darken the bubbles in the ORS **very carefully**.
7. Questions Q.1 – Q.25 carry 1 mark each. Questions Q.26 – Q.55 carry 2 marks each. The 2 marks questions include two pairs of common data questions and two pairs of linked answer questions. The answer to the second question of the linked answer questions depends on the answer to the first question of the pair. If the first question in the linked pair is wrongly answered or is unattempted, then the answer to the second question in the pair will not be evaluated.
8. Questions Q.56 – Q.65 belong to General Aptitude (GA) section and carry a total of 15 marks. Questions Q.56 – Q.60 carry 1 mark each, and questions Q.61 – Q.65 carry 2 marks each.
9. Unattempted questions will result in zero mark and wrong answers will result in **NEGATIVE** marks. For all 1 mark questions,  $\frac{1}{3}$  mark will be deducted for each wrong answer. For all 2 marks questions,  $\frac{2}{3}$  mark will be deducted for each wrong answer. However, in the case of the linked answer question pair, there will be negative marks only for wrong answer to the first question and no negative marks for wrong answer to the second question.
10. Calculator is allowed whereas charts, graph sheets or tables are **NOT** allowed in the examination hall.
11. Rough work can be done on the question paper itself. Blank pages are provided at the end of the question paper for rough work.
12. Before the start of the examination, write your name and registration number in the space provided below using a black ink ball point pen.

<b>Name</b>							
<b>Registration Number</b>	<b>ME</b>						

**Q. 1 – Q. 25 carry one mark each.**

- Q.1 In abrasive jet machining, as the distance between the nozzle tip and the work surface increases, the material removal rate
- (A) increases continuously.  
 (B) decreases continuously.  
 (C) decreases, becomes stable and then increases.  
 (D) increases, becomes stable and then decreases.

- Q.2 Match the following metal forming processes with their associated stresses in the workpiece.

Metal forming process	Type of stress
1. Coining	P. Tensile
2. Wire Drawing	Q. Shear
3. Blanking	R. Tensile and compressive
4. Deep Drawing	S. Compressive

(A) 1-S, 2-P, 3-Q, 4-R                      (B) 1-S, 2-P, 3-R, 4-Q  
 (C) 1-P, 2-Q, 3-S, 4-R                      (D) 1-P, 2-R, 3-Q, 4-S

- Q.3 In an interchangeable assembly, shafts of size  $25.000^{+0.040}_{-0.010}$  mm mate with holes of size  $25.000^{+0.030}_{+0.020}$  mm. The maximum interference (in microns) in the assembly is
- (A) 40                      (B) 30                      (C) 20                      (D) 10

- Q.4 During normalizing process of steel, the specimen is heated
- (A) between the upper and lower critical temperature and cooled in still air.  
 (B) above the upper critical temperature and cooled in furnace.  
 (C) above the upper critical temperature and cooled in still air.  
 (D) between the upper and lower critical temperature and cooled in furnace.

- Q.5 Oil flows through a 200 mm diameter horizontal cast iron pipe (friction factor,  $f = 0.0225$ ) of length 500 m. The volumetric flow rate is  $0.2 \text{ m}^3/\text{s}$ . The head loss (in m) due to friction is (assume  $g = 9.81 \text{ m/s}^2$ )
- (A) 116.18                      (B) 0.116                      (C) 18.22                      (D) 232.36

- Q.6 For an opaque surface, the absorptivity ( $\alpha$ ), transmissivity ( $\tau$ ) and reflectivity ( $\rho$ ) are related by the equation:
- (A)  $\alpha + \rho = \tau$                       (B)  $\rho + \alpha + \tau = 0$                       (C)  $\alpha + \rho = 1$                       (D)  $\alpha + \rho = 0$

- Q.7 Steam enters an adiabatic turbine operating at steady state with an enthalpy of 3251.0 kJ/kg and leaves as a saturated mixture at 15 kPa with quality (dryness fraction) 0.9. The enthalpies of the saturated liquid and vapor at 15 kPa are  $h_f = 225.94 \text{ kJ/kg}$  and  $h_g = 2598.3 \text{ kJ/kg}$  respectively. The mass flow rate of steam is 10 kg/s. Kinetic and potential energy changes are negligible. The power output of the turbine in MW is
- (A) 6.5                      (B) 8.9                      (C) 9.1                      (D) 27.0

- Q.8 The following are the data for two crossed helical gears used for speed reduction:  
 Gear I : Pitch circle diameter in the plane of rotation 80 mm and helix angle 30°  
 Gear II : Pitch circle diameter in the plane of rotation 120 mm and helix angle 22.5°  
 If the input speed is 1440 rpm, the output speed in rpm is  
 (A) 1200 (B) 900 (C) 875 (D) 720
- Q.9 A solid disc of radius  $r$  rolls without slipping on a horizontal floor with angular velocity  $\omega$  and angular acceleration  $\alpha$ . The magnitude of the acceleration of the point of contact on the disc is  
 (A) zero (B)  $r\alpha$  (C)  $\sqrt{(r\alpha)^2 + (r\omega^2)^2}$  (D)  $r\omega^2$
- Q.10 A thin walled spherical shell is subjected to an internal pressure. If the radius of the shell is increased by 1% and the thickness is reduced by 1%, with the internal pressure remaining the same, the percentage change in the circumferential (hoop) stress is  
 (A) 0 (B) 1 (C) 1.08 (D) 2.02
- Q.11 The area enclosed between the straight line  $y = x$  and the parabola  $y = x^2$  in the  $x$ - $y$  plane is  
 (A) 1/6 (B) 1/4 (C) 1/3 (D) 1/2
- Q.12 Consider the function  $f(x) = |x|$  in the interval  $-1 \leq x \leq 1$ . At the point  $x = 0$ ,  $f(x)$  is  
 (A) continuous and differentiable.  
 (B) non-continuous and differentiable.  
 (C) continuous and non-differentiable.  
 (D) neither continuous nor differentiable.
- Q.13 Which one of the following is **NOT** a decision taken during the aggregate production planning stage?  
 (A) Scheduling of machines (B) Amount of labour to be committed  
 (C) Rate at which production should happen (D) Inventory to be carried forward
- Q.14  $\lim_{x \rightarrow 0} \left( \frac{1 - \cos x}{x^2} \right)$  is  
 (A) 1/4 (B) 1/2 (C) 1 (D) 2
- Q.15 A CNC vertical milling machine has to cut a straight slot of 10 mm width and 2 mm depth by a cutter of 10 mm diameter between points (0, 0) and (100, 100) on the XY plane (dimensions in mm). The feed rate used for milling is 50 mm/min. Milling time for the slot (in seconds) is  
 (A) 120 (B) 170 (C) 180 (D) 240
- Q.16 A solid cylinder of diameter 100 mm and height 50 mm is forged between two frictionless flat dies to a height of 25 mm. The percentage change in diameter is  
 (A) 0 (B) 2.07 (C) 20.7 (D) 41.4

- Q.17 The velocity triangles at the inlet and exit of the rotor of a turbomachine are shown.  $V$  denotes the absolute velocity of the fluid,  $W$  denotes the relative velocity of the fluid and  $U$  denotes the blade velocity. Subscripts 1 and 2 refer to inlet and outlet respectively. If  $V_2 = W_1$  and  $V_1 = W_2$ , then the degree of reaction is

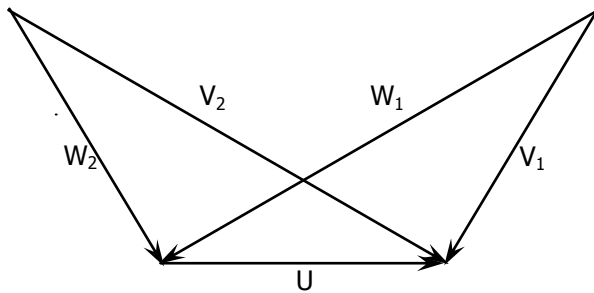

- (A) 0 (B) 1 (C) 0.5 (D) 0.25
- Q.18 Which one of the following configurations has the highest fin effectiveness?
- (A) Thin, closely spaced fins (B) Thin, widely spaced fins  
(C) Thick, widely spaced fins (D) Thick, closely spaced fins
- Q.19 An ideal gas of mass  $m$  and temperature  $T_1$  undergoes a reversible isothermal process from an initial pressure  $P_1$  to final pressure  $P_2$ . The heat loss during the process is  $Q$ . The entropy change  $\Delta S$  of the gas is
- (A)  $mR \ln \left( \frac{P_2}{P_1} \right)$  (B)  $mR \ln \left( \frac{P_1}{P_2} \right)$   
(C)  $mR \ln \left( \frac{P_2}{P_1} \right) - \frac{Q}{T_1}$  (D) zero
- Q.20 In the mechanism given below, if the angular velocity of the eccentric circular disc is  $1 \text{ rad/s}$ , the angular velocity ( $\text{rad/s}$ ) of the follower link for the instant shown in the figure is

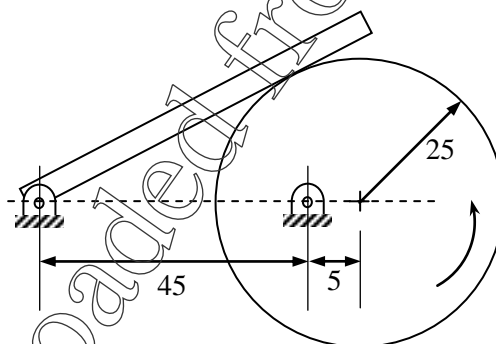

**Note:** All dimensions are in  $\text{mm}$ .

- (A) 0.05 (B) 0.1 (C) 5.0 (D) 10.0

- Q.21 A circular solid disc of uniform thickness  $20 \text{ mm}$ , radius  $200 \text{ mm}$  and mass  $20 \text{ kg}$ , is used as a flywheel. If it rotates at  $600 \text{ rpm}$ , the kinetic energy of the flywheel, in *Joules* is
- (A) 395 (B) 790  
(C) 1580 (D) 3160
- Q.22 A cantilever beam of length  $L$  is subjected to a moment  $M$  at the free end. The moment of inertia of the beam cross section about the neutral axis is  $I$  and the Young's modulus is  $E$ . The magnitude of the maximum deflection is
- (A)  $\frac{ML^2}{2EI}$  (B)  $\frac{ML^2}{EI}$  (C)  $\frac{2ML^2}{EI}$  (D)  $\frac{4ML^2}{EI}$
- Q.23 For a long slender column of uniform cross section, the ratio of critical buckling load for the case with both ends clamped to the case with both ends hinged is
- (A) 1 (B) 2 (C) 4 (D) 8
- Q.24 At  $x = 0$ , the function  $f(x) = x^3 + 1$  has
- (A) a maximum value (B) a minimum value  
(C) a singularity (D) a point of inflection
- Q.25 For the spherical surface  $x^2 + y^2 + z^2 = 1$ , the unit outward normal vector at the point  $(\frac{1}{\sqrt{2}}, \frac{1}{\sqrt{2}}, 0)$  is given by
- (A)  $\frac{1}{\sqrt{2}}\hat{i} + \frac{1}{\sqrt{2}}\hat{j}$  (B)  $\frac{1}{\sqrt{2}}\hat{i} - \frac{1}{\sqrt{2}}\hat{j}$   
(C)  $\hat{k}$  (D)  $\frac{1}{\sqrt{3}}\hat{i} + \frac{1}{\sqrt{3}}\hat{j} + \frac{1}{\sqrt{3}}\hat{k}$

**Q. 26 - Q. 55 carry two marks each.**

Q.26 The homogeneous state of stress for a metal part undergoing plastic deformation is

$$T = \begin{pmatrix} 10 & 5 & 0 \\ 5 & 20 & 0 \\ 0 & 0 & -10 \end{pmatrix},$$

where the stress component values are in *MPa*. Using von Mises yield criterion, the value of estimated shear yield stress, in *MPa* is

- (A) 9.50                      (B) 16.07                      (C) 28.52                      (D) 49.41

Q.27 Details pertaining to an orthogonal metal cutting process are given below.

Chip thickness ratio	0.4
Undeformed thickness	0.6 mm
Rake angle	+10°
Cutting speed	2.5 m/s
Mean thickness of primary shear zone	25 microns

The shear strain rate in  $s^{-1}$  during the process is

- (A)  $0.1781 \times 10^5$                       (B)  $0.7754 \times 10^5$                       (C)  $1.0104 \times 10^5$                       (D)  $4.397 \times 10^5$

Q.28 In a single pass drilling operation, a through hole of 15 mm diameter is to be drilled in a steel plate of 50 mm thickness. Drill spindle speed is 500 rpm, feed is 0.2 mm/rev and drill point angle is 118°. Assuming 2 mm clearance at approach and exit, the total drill time (in seconds) is

- (A) 35.1                      (B) 32.4                      (C) 31.2                      (D) 30.1

Q.29 Consider two infinitely long thin concentric tubes of circular cross section as shown in the figure. If  $D_1$  and  $D_2$  are the diameters of the inner and outer tubes respectively, then the view factor  $F_{22}$  is given by

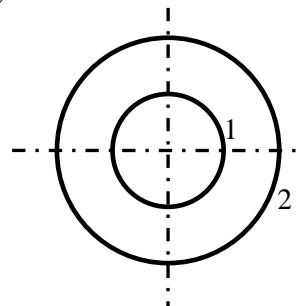

- (A)  $\left(\frac{D_2}{D_1}\right)^{-1}$                       (B) zero                      (C)  $\left(\frac{D_1}{D_2}\right)$                       (D)  $1 - \left(\frac{D_1}{D_2}\right)$

Q.30 An incompressible fluid flows over a flat plate with zero pressure gradient. The boundary layer thickness is  $1 \text{ mm}$  at a location where the Reynolds number is 1000. If the velocity of the fluid alone is increased by a factor of 4, then the boundary layer thickness at the same location, in  $\text{mm}$  will be

- (A) 4 (B) 2 (C) 0.5 (D) 0.25

Q.31 A room contains  $35 \text{ kg}$  of dry air and  $0.5 \text{ kg}$  of water vapor. The total pressure and temperature of air in the room are  $100 \text{ kPa}$  and  $25^\circ\text{C}$  respectively. Given that the saturation pressure for water at  $25^\circ\text{C}$  is  $3.17 \text{ kPa}$ , the relative humidity of the air in the room is

- (A) 67% (B) 55% (C) 83% (D) 71%

Q.32 A fillet welded joint is subjected to transverse loading  $F$  as shown in the figure. Both legs of the fillets are of  $10 \text{ mm}$  size and the weld length is  $30 \text{ mm}$ . If the allowable shear stress of the weld is  $94 \text{ MPa}$ , considering the minimum throat area of the weld, the maximum allowable transverse load in  $\text{kN}$  is

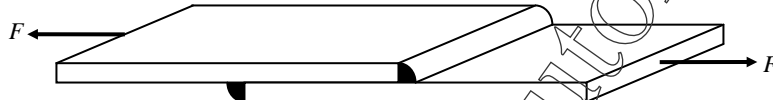

- (A) 14.44 (B) 17.92 (C) 19.93 (D) 22.16

Q.33 A concentrated mass  $m$  is attached at the centre of a rod of length  $2L$  as shown in the figure. The rod is kept in a horizontal equilibrium position by a spring of stiffness  $k$ . For very small amplitude of vibration, neglecting the weights of the rod and spring, the undamped natural frequency of the system is

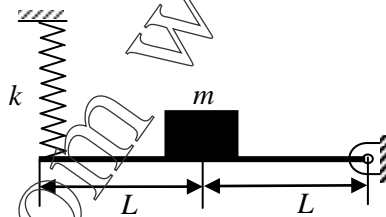

- (A)  $\sqrt{\frac{k}{m}}$  (B)  $\sqrt{\frac{2k}{m}}$  (C)  $\sqrt{\frac{k}{2m}}$  (D)  $\sqrt{\frac{4k}{m}}$

Q.34 The state of stress at a point under plane stress condition is

$$\sigma_{xx} = 40 \text{ MPa}, \sigma_{yy} = 100 \text{ MPa} \text{ and } \tau_{xy} = 40 \text{ MPa}.$$

The radius of the Mohr's circle representing the given state of stress in  $\text{MPa}$  is

- (A) 40 (B) 50 (C) 60 (D) 100

Q.35 The inverse Laplace transform of the function  $F(s) = \frac{1}{s(s+1)}$  is given by

- (A)  $f(t) = \sin t$  (B)  $f(t) = e^{-t} \sin t$   
 (C)  $f(t) = e^{-t}$  (D)  $f(t) = 1 - e^{-t}$

Q.36 For the matrix  $\mathbf{A} = \begin{bmatrix} 5 & 3 \\ 1 & 3 \end{bmatrix}$ , ONE of the normalized eigen vectors is given as

(A)  $\begin{pmatrix} \frac{1}{2} \\ \frac{\sqrt{3}}{2} \end{pmatrix}$

(B)  $\begin{pmatrix} \frac{1}{\sqrt{2}} \\ -\frac{1}{\sqrt{2}} \end{pmatrix}$

(C)  $\begin{pmatrix} \frac{3}{\sqrt{10}} \\ -\frac{1}{\sqrt{10}} \end{pmatrix}$

(D)  $\begin{pmatrix} \frac{1}{\sqrt{5}} \\ \frac{2}{\sqrt{5}} \end{pmatrix}$

Q.37 Calculate the punch size in  $mm$ , for a circular blanking operation for which details are given below.

Size of the blank	25 mm
Thickness of the sheet	2 mm
Radial clearance between punch and die	0.06 mm
Die allowance	0.05 mm

- (A) 24.83                      (B) 24.89                      (C) 25.01                      (D) 25.17

Q.38 In a single pass rolling process using 410 mm diameter steel rollers, a strip of width 140 mm and thickness 8 mm undergoes 10 % reduction of thickness. The angle of bite in radians is

- (A) 0.006                      (B) 0.031                      (C) 0.062°                      (D) 0.600

Q.39 In a DC arc welding operation, the voltage-arc length characteristic was obtained as  $V_{arc} = 20 + 5l$  where the arc length  $l$  was varied between 5 mm and 7 mm. Here  $V_{arc}$  denotes the arc voltage in Volts. The arc current was varied from 400 A to 500 A. Assuming linear power source characteristic, the open circuit voltage and the short circuit current for the welding operation are

- (A) 45 V, 450 A                      (B) 75 V, 750 A                      (C) 95 V, 950 A                      (D) 150 V, 1500 A

Q.40 A large tank with a nozzle attached contains three immiscible, inviscid fluids as shown. Assuming that the changes in  $h_1$ ,  $h_2$  and  $h_3$  are negligible, the instantaneous discharge velocity is

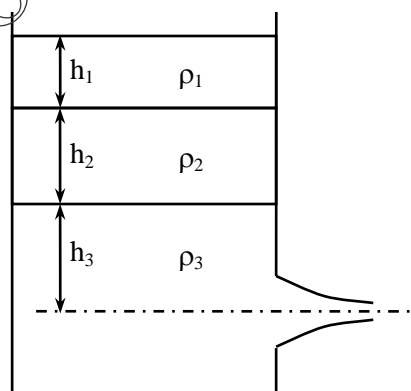

(A)  $\sqrt{2gh_3 \left( 1 + \frac{\rho_1 h_1}{\rho_3 h_3} + \frac{\rho_2 h_2}{\rho_3 h_3} \right)}$

(B)  $\sqrt{2g(h_1 + h_2 + h_3)}$

(C)  $\sqrt{2g \left( \frac{\rho_1 h_1 + \rho_2 h_2 + \rho_3 h_3}{\rho_1 + \rho_2 + \rho_3} \right)}$

(D)  $\sqrt{2g \left( \frac{\rho_1 h_2 h_3 + \rho_2 h_3 h_1 + \rho_3 h_1 h_2}{\rho_1 h_1 + \rho_2 h_2 + \rho_3 h_3} \right)}$



- Q.41 Water ( $C_p = 4.18 \text{ kJ/kg.K}$ ) at  $80^\circ\text{C}$  enters a counterflow heat exchanger with a mass flow rate of  $0.5 \text{ kg/s}$ . Air ( $C_p = 1 \text{ kJ/kg.K}$ ) enters at  $30^\circ\text{C}$  with a mass flow rate of  $2.09 \text{ kg/s}$ . If the effectiveness of the heat exchanger is 0.8, the LMTD (in  $^\circ\text{C}$ ) is
- (A) 40 (B) 20 (C) 10 (D) 5
- Q.42 A solid steel cube constrained on all six faces is heated so that the temperature rises uniformly by  $\Delta T$ . If the thermal coefficient of the material is  $\alpha$ , Young's modulus is  $E$  and the Poisson's ratio is  $\nu$ , the thermal stress developed in the cube due to heating is
- (A)  $-\frac{\alpha(\Delta T)E}{(1-2\nu)}$  (B)  $-\frac{2\alpha(\Delta T)E}{(1-2\nu)}$  (C)  $-\frac{3\alpha(\Delta T)E}{(1-2\nu)}$  (D)  $-\frac{\alpha(\Delta T)E}{3(1-2\nu)}$
- Q.43 A solid circular shaft needs to be designed to transmit a torque of  $50 \text{ N.m}$ . If the allowable shear stress of the material is  $140 \text{ MPa}$ , assuming a factor of safety of 2, the minimum allowable design diameter in  $\text{mm}$  is
- (A) 8 (B) 16 (C) 24 (D) 32
- Q.44 A force of  $400 \text{ N}$  is applied to the brake drum of  $0.5 \text{ m}$  diameter in a band-brake system as shown in the figure, where the wrapping angle is  $180^\circ$ . If the coefficient of friction between the drum and the band is 0.25, the braking torque applied, in  $\text{N.m}$  is

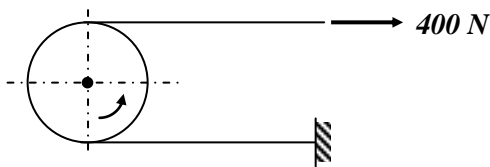

- (A) 100.6 (B) 54.4 (C) 22.1 (D) 15.7
- Q.45 A box contains 4 red balls and 6 black balls. Three balls are selected randomly from the box one after another, without replacement. The probability that the selected set contains one red ball and two black balls is
- (A)  $1/20$  (B)  $1/12$  (C)  $3/10$  (D)  $1/2$
- Q.46 Consider the differential equation  $x^2 \frac{d^2 y}{dx^2} + x \frac{dy}{dx} - 4y = 0$  with the boundary conditions of  $y(0) = 0$  and  $y(1) = 1$ . The complete solution of the differential equation is
- (A)  $x^2$  (B)  $\sin\left(\frac{\pi x}{2}\right)$  (C)  $e^x \sin\left(\frac{\pi x}{2}\right)$  (D)  $e^{-x} \sin\left(\frac{\pi x}{2}\right)$
- Q.47
- $$\begin{aligned} x + 2y + z &= 4 \\ 2x + y + 2z &= 5 \\ x - y + z &= 1 \end{aligned}$$

The system of algebraic equations given above has

- (A) a unique solution of  $x = 1$ ,  $y = 1$  and  $z = 1$ .  
 (B) only the two solutions of  $(x = 1, y = 1, z = 1)$  and  $(x = 2, y = 1, z = 0)$ .  
 (C) infinite number of solutions.  
 (D) no feasible solution.

### Common Data Questions

#### Common Data for Questions 48 and 49:

Two steel truss members, AC and BC, each having cross sectional area of  $100 \text{ mm}^2$ , are subjected to a horizontal force  $F$  as shown in figure. All the joints are hinged.

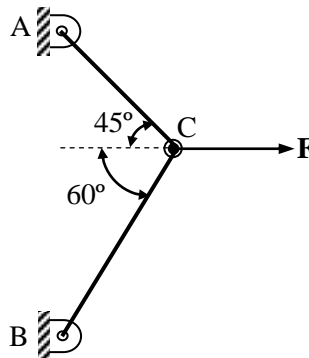

- Q.48 If  $F = 1 \text{ kN}$ , the magnitude of the vertical reaction force developed at the point B in  $\text{kN}$  is  
 (A) 0.63 (B) 0.32 (C) 1.26 (D) 1.46
- Q.49 The maximum force  $F$  in  $\text{kN}$  that can be applied at C such that the axial stress in any of the truss members DOES NOT exceed  $100 \text{ MPa}$  is  
 (A) 8.17 (B) 11.15 (C) 14.14 (D) 22.30

#### Common Data for Questions 50 and 51:

A refrigerator operates between  $120 \text{ kPa}$  and  $800 \text{ kPa}$  in an ideal vapor compression cycle with R-134a as the refrigerant. The refrigerant enters the compressor as saturated vapor and leaves the condenser as saturated liquid. The mass flow rate of the refrigerant is  $0.2 \text{ kg/s}$ . Properties for R-134a are as follows:

Saturated R-134a					
$P \text{ (kPa)}$	$T \text{ (}^\circ\text{C)}$	$h_f \text{ (kJ/kg)}$	$h_g \text{ (kJ/kg)}$	$s_f \text{ (kJ/kg.K)}$	$s_g \text{ (kJ/kg.K)}$
120	-22.32	22.5	237	0.093	0.95
800	31.31	95.5	267.3	0.354	0.918
Superheated R-134a					
$P \text{ (kPa)}$	$T \text{ (}^\circ\text{C)}$	$h \text{ (kJ/kg)}$		$s \text{ (kJ/kg.K)}$	
800	40	276.45		0.95	

- Q.50 The rate at which heat is extracted, in  $\text{kJ/s}$  from the refrigerated space is  
 (A) 28.3 (B) 42.9 (C) 34.4 (D) 14.6
- Q.51 The power required for the compressor in  $\text{kW}$  is  
 (A) 5.94 (B) 1.83 (C) 7.9 (D) 39.5

## Linked Answer Questions

### Statement for Linked Answer Questions 52 and 53:

Air enters an adiabatic nozzle at 300 kPa, 500 K with a velocity of 10 m/s. It leaves the nozzle at 100 kPa with a velocity of 180 m/s. The inlet area is 80 cm<sup>2</sup>. The specific heat of air  $C_p$  is 1008 J/kg.K.

Q.52 The exit temperature of the air is

- (A) 516 K                      (B) 532 K                      (C) 484 K                      (D) 468 K

Q.53 The exit area of the nozzle in cm<sup>2</sup> is

- (A) 90.1                      (B) 56.3                      (C) 4.4                      (D) 12.9

### Statement for Linked Answer Questions 54 and 55:

For a particular project, eight activities are to be carried out. Their relationships with other activities and expected durations are mentioned in the table below.

Activity	Predecessors	Duration (days)
a	-	3
b	a	4
c	a	5
d	a	4
e	b	2
f	d	9
g	c, e	6
h	f, g	2

Q.54 The critical path for the project is

- (A) a – b – e – g – h                      (B) a – c – g – h  
(C) a – d – f – h                      (D) a – b – c – f – h

Q.55 If the duration of activity f alone is changed from 9 to 10 days, then the

- (A) critical path remains the same and the total duration to complete the project changes to 19 days.  
(B) critical path and the total duration to complete the project remain the same.  
(C) critical path changes but the total duration to complete the project remains the same.  
(D) critical path changes and the total duration to complete the project changes to 17 days.

## General Aptitude (GA) Questions

### Q. 56 – Q. 60 carry one mark each.

Q.56 Choose the most appropriate alternative from the options given below to complete the following sentence:

**Suresh's dog is the one \_\_\_\_\_ was hurt in the stampede.**

- (A) that                      (B) which                      (C) who                      (D) whom

Q.57 The cost function for a product in a firm is given by  $5q^2$ , where  $q$  is the amount of production. The firm can sell the product at a market price of ₹ 50 per unit. The number of units to be produced by the firm such that the profit is maximized is

- (A) 5                      (B) 10                      (C) 15                      (D) 25

Q.58 Choose the most appropriate alternative from the options given below to complete the following sentence:

**Despite several \_\_\_\_\_ the mission succeeded in its attempt to resolve the conflict.**

- (A) attempts                      (B) setbacks                      (C) meetings                      (D) delegations

Q.59 Which one of the following options is the closest in meaning to the word given below?

**Mitigate**

- (A) Diminish                      (B) Divulge                      (C) Dedicate                      (D) Denote

Q.60 Choose the grammatically **INCORRECT** sentence:

- (A) They gave us the money back less the service charges of Three Hundred rupees.  
 (B) This country's expenditure is not less than that of Bangladesh.  
 (C) The committee initially asked for a funding of Fifty Lakh rupees, but later settled for a lesser sum.  
 (D) This country's expenditure on educational reforms is very less.

### Q. 61 - Q. 65 carry two marks each.

Q.61 Given the sequence of terms, AD CG FK JP, the next term is

- (A) OV                      (B) OW                      (C) PV                      (D) PW

Q.62 **Wanted Temporary, Part-time persons for the post of Field Interviewer to conduct personal interviews to collect and collate economic data. Requirements: High School-pass, must be available for Day, Evening and Saturday work. Transportation paid, expenses reimbursed.**

Which one of the following is the best inference from the above advertisement?

- (A) Gender-discriminatory  
 (B) Xenophobic  
 (C) Not designed to make the post attractive  
 (D) Not gender-discriminatory

Q.63 A political party orders an arch for the entrance to the ground in which the annual convention is being held. The profile of the arch follows the equation  $y = 2x - 0.1x^2$  where  $y$  is the height of the arch in meters. The maximum possible height of the arch is

- (A) 8 meters                      (B) 10 meters                      (C) 12 meters                      (D) 14 meters

Q.64 An automobile plant contracted to buy shock absorbers from two suppliers X and Y. X supplies 60% and Y supplies 40% of the shock absorbers. All shock absorbers are subjected to a quality test. The ones that pass the quality test are considered reliable. Of X's shock absorbers, 96% are reliable. Of Y's shock absorbers, 72% are reliable.

The probability that a randomly chosen shock absorber, which is found to be reliable, is made by Y is

- (A) 0.288                      (B) 0.334                      (C) 0.667                      (D) 0.720

Q.65 Which of the following assertions are **CORRECT**?

P: Adding 7 to each entry in a list adds 7 to the mean of the list

Q: Adding 7 to each entry in a list adds 7 to the standard deviation of the list

R: Doubling each entry in a list doubles the mean of the list

S: Doubling each entry in a list leaves the standard deviation of the list unchanged

- (A) P, Q                      (B) Q, R                      (C) P, R                      (D) R, S

**END OF THE QUESTION PAPER**

---

**Space for Rough Work**

Downloaded from [www.tutorialpoint.org](http://www.tutorialpoint.org)

**Space for Rough Work**

Downloaded from [www.tutorialpoint.org](http://www.tutorialpoint.org)

---

**Space for Rough Work**

Downloaded from [www.tutorialpoint.org](http://www.tutorialpoint.org)